

Cubicle USPs

Infinite - Real Wood Veneer, ColourCoat and Gloss

Floor clearance: 50mm

Ceiling clearance: 20mm minimum

Material thickness: 44mm fronts and 35mm partitions

Overview:

- Set back pedestals give a floating appearance and keep the cubicle façade clear, minimal and easy to clean
- Flush fronted with clean lines for a minimal look
- Rebated doors and pilasters eliminate sight lines and ensure absolute privacy
- No visible fixings
- Hardwood edged with handcrafted Veneer, ColourCoat or Gloss finishes
- Veneer option has natural warmth to the touch
- Bespoke height to suit ceiling height and give flexibility
- 35mm partitions and 44mm fronts give a superior furniture appearance and allow fixtures and fittings to be concealed within rebates
- Stainless steel flip-action indicator bolt with mortise lock -
 - Strong & robust
 - Gives a superior locking action
 - Fittings and mechanism are concealed inside the door
 - Can be operated with a closed fist
 - Has a clear red indicator when cubicle is engaged
 - Can be unlocked from the outside in an emergency
- Stainless steel, self-closing rise and fall butt hinges allow the door to fall into a closed position maintaining the flush fronted appearance when cubicles are not in use

Fittings:

Stainless Steel Lock and Hinges -

- Give a premium aesthetic to the cubicle façade
- Strong and robust

Satin Anodised Aluminium Pedestal, Headrail and Wall Channels -

- Bright and clean contemporary look
- Easy to clean
- Scratch resistant
- Will not show finger prints

Partition Wall Fixing:

Satin Anodised Gravity Channel with Aluminium Z-Clip Fixing -

- Discreet appearance
- Solid and robust when installed
- Allows complete privacy
- Extrusions are partly hidden within the partition
- Concealed fixings
- Easy to clean
- Simple installation

Pilaster Wall Fixing:

Satin Anodised Gravity Channel with Aluminium Z-Clip Fixing -

- Discreet appearance
- Solid and robust when installed
- Allows complete privacy
- Extrusions are partly hidden within the pilaster
- Concealed fixings
- Easy to clean
- Simple installation

Partition Floor Fixing:

Satin Anodised Aluminium Pedestals -

- Set back on partitions to give a floating appearance and keep the fronts clear and minimal
- Adjustable to accommodate uneven floors
- Sits into the partition giving a sturdy installation without visible fixings

Headrail:

Satin Anodised Aluminium Headrail -

- Unique 3 part headrail
- Allows cubicle to be fixed only 20mm from the ceiling
- Clip-in cover extrusion conceals fixings meaning they cannot be tampered with
- Cover extrusion hides all internal fixings giving the impression that the headrail is one part, keeping the neat appearance
- The square face complements Infinite's minimal façade

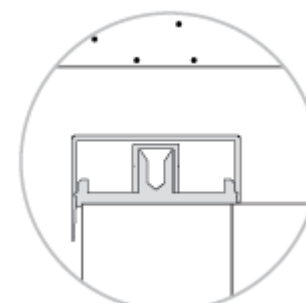
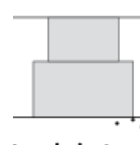
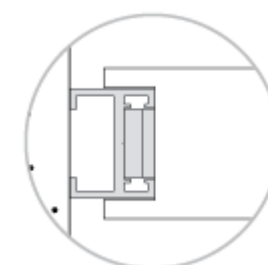
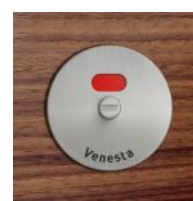
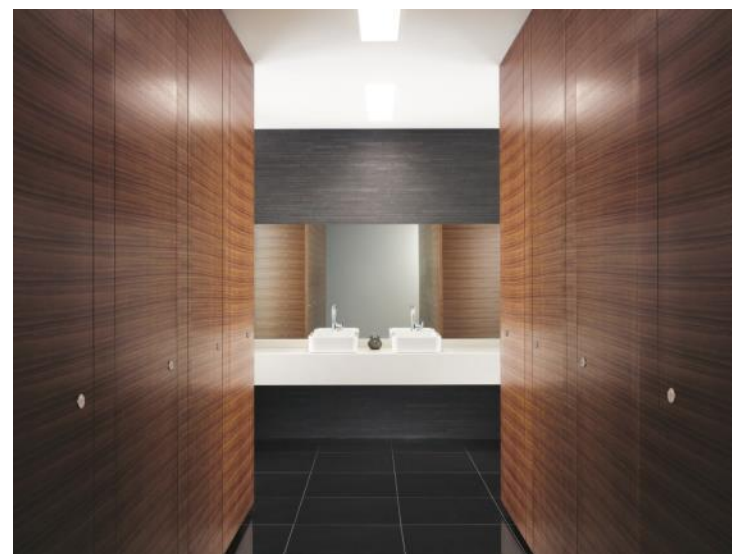

Cubicle USPs

Infinite Full Height - Real Wood Veneer, ColourCoat and Gloss

Floor clearance: 20mm

Ceiling clearance: 30mm

Material thickness: 44mm fronts and 35mm partitions

Overview:

- Floating appearance keeps the cubicle façade clear, minimal and easy to clean
- Flush fronted with clean lines for a minimal look
- Rebated doors and pilasters eliminate sight lines and ensure absolute privacy
- No headrail meaning that the lock fascia is the only part visible on the cubicle face
- No visible fixings
- Hardwood edged with handcrafted Veneer, ColourCoat or Gloss finishes
- Veneer option has natural warmth to the touch
- Bespoke height to suit ceiling height and give flexibility
- 35mm partitions and 44mm fronts give a superior furniture appearance and allow fixtures and fittings to be concealed within rebates
- Stainless steel flip-action indicator bolt with mortise lock -
 - Strong & robust
 - Gives a superior locking action
 - Fittings and mechanism are concealed inside the door
 - Can be operated with a closed fist
 - Has a clear red indicator when cubicle is engaged
 - Can be unlocked from the outside in an emergency
- Stainless steel, self-closing rise and fall butt hinges allow the door to fall into a closed position maintaining the flush fronted appearance when cubicles are not in use

Fittings:

Stainless Steel Lock, Hinges and Pilaster Fixings -

- Give a premium aesthetic to the cubicle façade
- Strong and robust

Satin Anodised Headrail and Wall Channels -

- Bright and clean contemporary look
- Easy to clean
- Scratch resistant
- Will not show finger prints

Partition Wall Fixing:

Satin Anodised Gravity Channel with Aluminium Z-Clip Fixing -

- Discreet appearance
- Solid and robust when installed
- Allows complete privacy
- Extrusions are partly hidden within the partition
- Concealed fixings
- Easy to clean
- Simple installation

Pilaster Wall Fixing:

Satin Anodised Gravity Channel with Aluminium Z-Clip Fixing -

- Discreet appearance
- Solid and robust when installed
- Allows complete privacy
- Extrusions are partly hidden within the pilaster
- Concealed fixings
- Easy to clean
- Simple installation

Partition Ceiling and Floor Fixing:

Satin Anodised Aluminium Ceiling Extrusion -

- Frames the cubicle partition
- Allows complete privacy
- Easy to install with groove to accept and guide countersunk screws
- Concealed fixings
- Easy to clean
- Keeps timber off the floor so it will not be damaged by cleaning

Pilaster Ceiling and Floor Fixing:

Stainless Steel Floor Block -

- Fits neatly into rebates at the top and bottom of the pilaster
- Easy to fix
- Strong and robust
- Concealed fixings
- A discreet support for pilasters, allowing the cubicle to be secured without a headrail
- Stainless steel to complement the cubicle hinges and lock

